



**ADOIL** INC.  
OILWELL ENVIRONMENTAL PRODUCTS  
AN ISO 9001 COMPANY

**“ Prevent what you  
can’t predict at  
your oilwell ”**

**TITAN**®  
WELLHEAD CONTAINMENT SYSTEM

# Why Wellhead Containment?

- Wellhead leakage is a messy and costly problem for the oil industry.
- Steam cleaning washes leakage from the wellhead deep into the soil.
- Only surface soil is removed and replaced, leaving deeper contaminated layers behind.
- Wellhead is clean but the underground soil remains contaminated.
- Entire clean up process is repeated up to 6-12 months later and costs between \$3000-\$6000.

**Don't wait until your well makes headlines, implement simplified protection.**

**Wellhead containment is suitable for all oil wells and paramount in environmentally sensitive areas.**



**AD OIL** INC.  
OILWELL ENVIRONMENTAL PRODUCTS  
AN ISO 9001 COMPANY

**Produced Water is More Damaging to the Environment than Oil**

# TITAN<sup>®</sup> Sizes

- Powder-Coated Aluminum base
- 360° transparent UV-Resistant Polycarbonate Top
- High-Level Shutdown Switch
- Complete with Stainless Steel Fittings (incl. Ball Valve)
- Installation Kit included

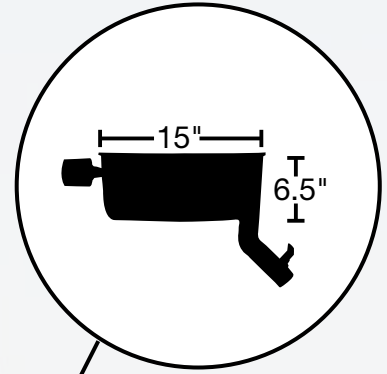

TITAN<sup>®</sup> is the only wellhead containment system constructed of solid Aluminum Alloys  
Made in North America

## NO BOLTS, NO SCREWS, NO FUSS, NO LEAKS

**Tight space?  
The shorty  
allows for a  
low clearance  
carrier bar.**

**The Original;  
perfect for  
most wells.**

**Tall Top;  
allows for the  
use of rod  
lubricator.**



**1958SHT  
Shorty**



**1958T  
Regular**

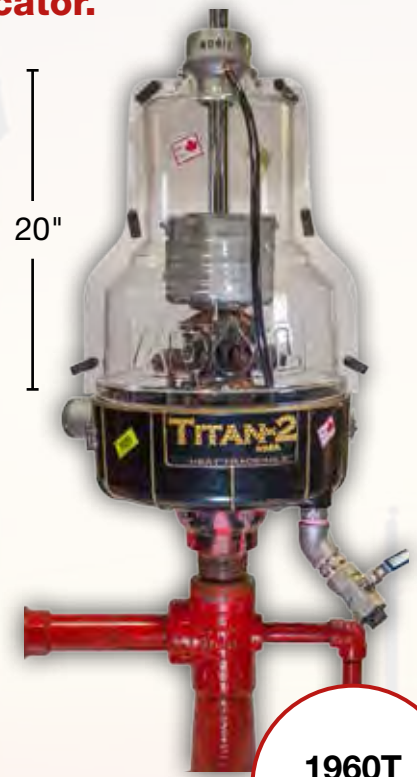

**1960T  
Extended**

# Optional Features

## RAIN DRAIN

- Helps eliminate unnecessary shutdowns caused by rainwater collection during Spring and Summer
- Available with seals for 1 1/4" and 1 1/2" rod sizes



## TANKS

*\*Built in  
Shutdown  
switch option  
available for  
both sizes*



### Standard 10 Gallon Tank

- Easy to drain ball valve
- All weather flex hose
- Optional Stand



### Large 50 Gallon Tank

- 4" Manway for Vacuum truck
- All weather flex hose

## HIGH LEVEL FLOAT

- Standard in all TITAN® Units
- Cost effective
- CSA Class 1-Div 1 Approved



- Upgraded switch option
- Better suited to withstand extreme temperatures
- Rust resistant
- CSA Class 1-Div 1 Approved

## SONIC SWITCH

# Stuffing Boxes

Made to fit Dual Pack stuffing boxes, easy-to-install adapters allow fit to ALL industry stuffing box and flow-T types.



**Production  
Safety-Supply  
LTD. Model HT  
Stuffing Box**



**Red Wing  
Stuffing Box**



**Harbison-Fisher:  
Quick-seal box,  
"Opel"**



**Harbison-Fisher:  
Injecta-Box**



**Big Stuff Dual  
Pack Hercules  
Stuffing Box**



**Single Pac  
Hercules  
Stuffing Box**



**Dual Pac  
Hercules  
Stuffing Box**



**Nelgar Rod  
Knuckle  
Stuffing Box**



**Flow-T Metal  
to Metal  
Mount**

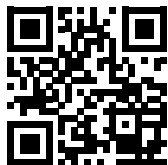

Watch our quick and easy TITAN® installation videos at  
**[www.adoil.net](http://www.adoil.net)**





ADOIL products are available at your local oilfield supply stores, including:



[www.adoil.net](http://www.adoil.net)



B11 - 416 Meridian Road SE  
Calgary, AB T2A 1X2

P: 403-242-2201 F: 403-217-8868



ADOIL Inc. PRODUCTS ARE ALL PROTECTED BY PAT. & PAT.PENDING LAWS